

BARREL TENSIONER INSTALLATION INSTRUCTIONS

for One-Way and Two-Way Barrel Tensioners

HARDWARE INCLUDED FOR BARREL TENSIONERS



4" L x 1/2" Lag Screw



1" O.D. Washer

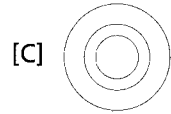

Plastic Grommet

STEP ① DETERMINING BARREL TENSIONER LOCATIONS

1. Pilot holes must be drilled first. To do this, position the top rail of fencing, making sure it lines up correctly. Mark the top of the rail on the post as shown in **Illustration 1-A**.
2. Measure down 2.5 inches from the mark as shown in **Illustration 1-B**. This mark is where the first pilot hole will be drilled. For additional barrel tensioners, use the same spacing that was used when installing fence brackets.

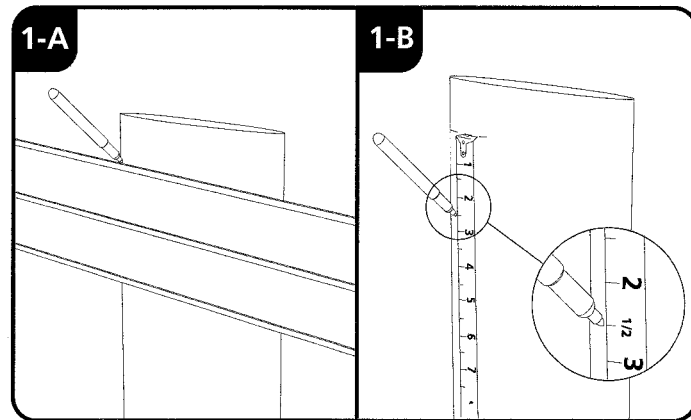

STEP ② ATTACHING BARREL TENSIONERS TO POST

1. Using a 3/8" drill bit, drill pilot holes for all barrel tensioners.
2. Attach the barrel tensioners using the supplied lag screw [A] washer [B], and plastic grommet [C] in the order shown in **Illustration 2-A**.
3. The two-way barrel tensioner should be mounted as shown in **Illustration 2-B**, making sure the locking block is facing down toward the ground.
4. The one-way barrel tensioner can be mounted facing left (as shown in **Illustration 2-C**) or right, depending on the location of the fence.

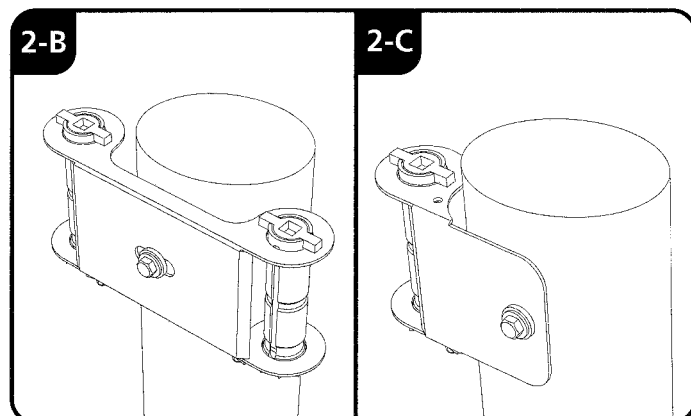
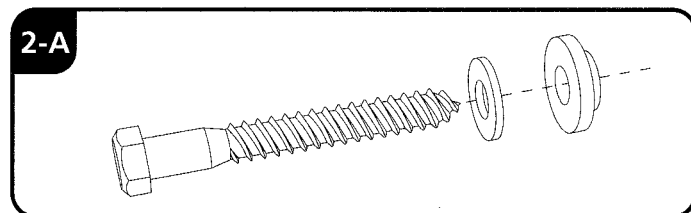

NOTE: Make sure the locking block is always facing toward the ground. This can be achieved by unscrewing the bolt that holds the locking block and moving it to the opposite hole on the tensioner bracket. The barrel assembly must also be flipped by straightening and removing the copper pin, flipping the barrel assembly and reinserting the pin.

NOTE: Do NOT overtighten lag screw. Barrel tensioners should fit snug to post, but still be able to move with slight pressure.

BARREL TENSIONER INSTALLATION INSTRUCTIONS

for One-Way and Two-Way Barrel Tensioners

STEP ③ MARK AND CUT RAIL

1. Hold rail up to barrel tensioners and mark the rail as shown in **Illustrations 3-A and 3-B**. If the fence you are tensioning is less than 200' long, then mark the fence at line A (right next to the lag screw). Mark it at line B (halfway between the lag screw and the edge of the bracket) if the fence is 200' - 450' long. Mark the fence at line C (even with the edge of the bracket) if the fence is 450' - 660' long.
2. Once the rail is marked, cut the polymer using a straight edge to ensure the end of the rail will be square. Cut the excess wire off using wire cutters.

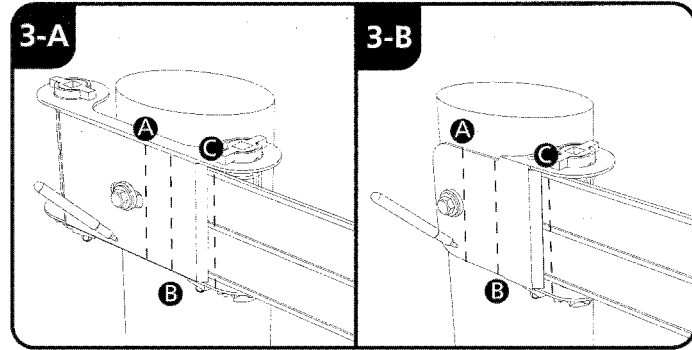

STEP ④ TENSIONING RAIL

1. Insert end of rail into slot on barrel as shown in **Illustration 4-A**. Next, insert a 1/2" drive ratchet into the square hole on the end of the barrel. Begin turning the barrel to wrap the rail around it as shown in **Illustration 4-B**. Use the square locking block on the bottom of the barrel to prevent the rail from uncoiling as it is tensioned.

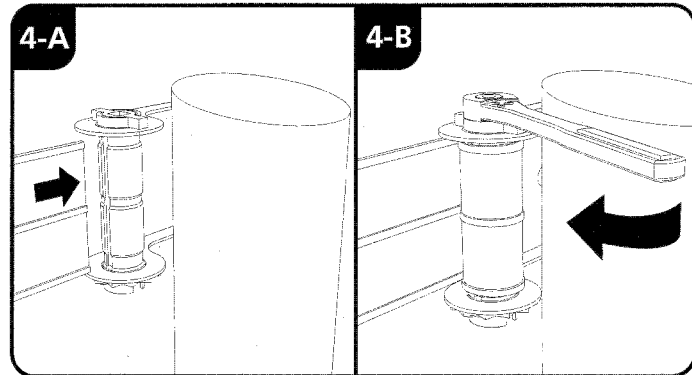

2. **IMPORTANT:** When tensioning a two-way barrel tensioner, be sure to apply tension in small increments to both sides to avoid causing the post to lean or break off. See **Illustration 4-C**.

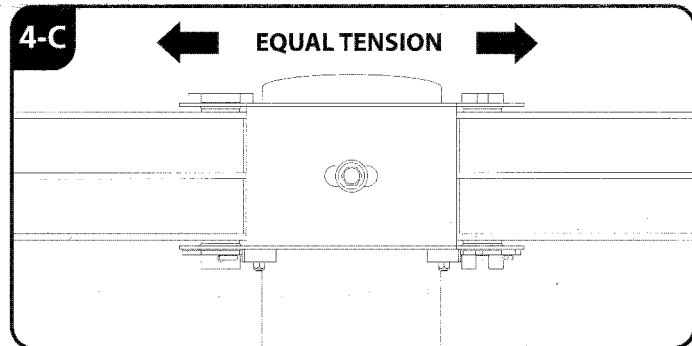

3. Continue to coil rail onto barrels until the rail is satisfactorily tight. Do NOT overtighten the rail, as this will reduce the flexibility of your Centaur fence. **Photo 4-D** shows a finished fence with tensioner assemblies.

